



FONG PREAN INDUSTRIAL CO.,LTD.

*We live for solving problems.
Fastener manufacturer in Taiwan since 1986*



CONTACT US:

Phone : +886-7-6170526

Email :
export3@ms.fongprean.com.tw

Address :
No.6, Gongwei St., Ziguan Dist.,
Kaohsiung City, 826012
Taiwan



SGS ISO9001:2015 / SGS ISO14001:2015
CE EN 14592 / CE EN14566 / ETA-20/0408



www.fongprean.com

www.fongprean.com

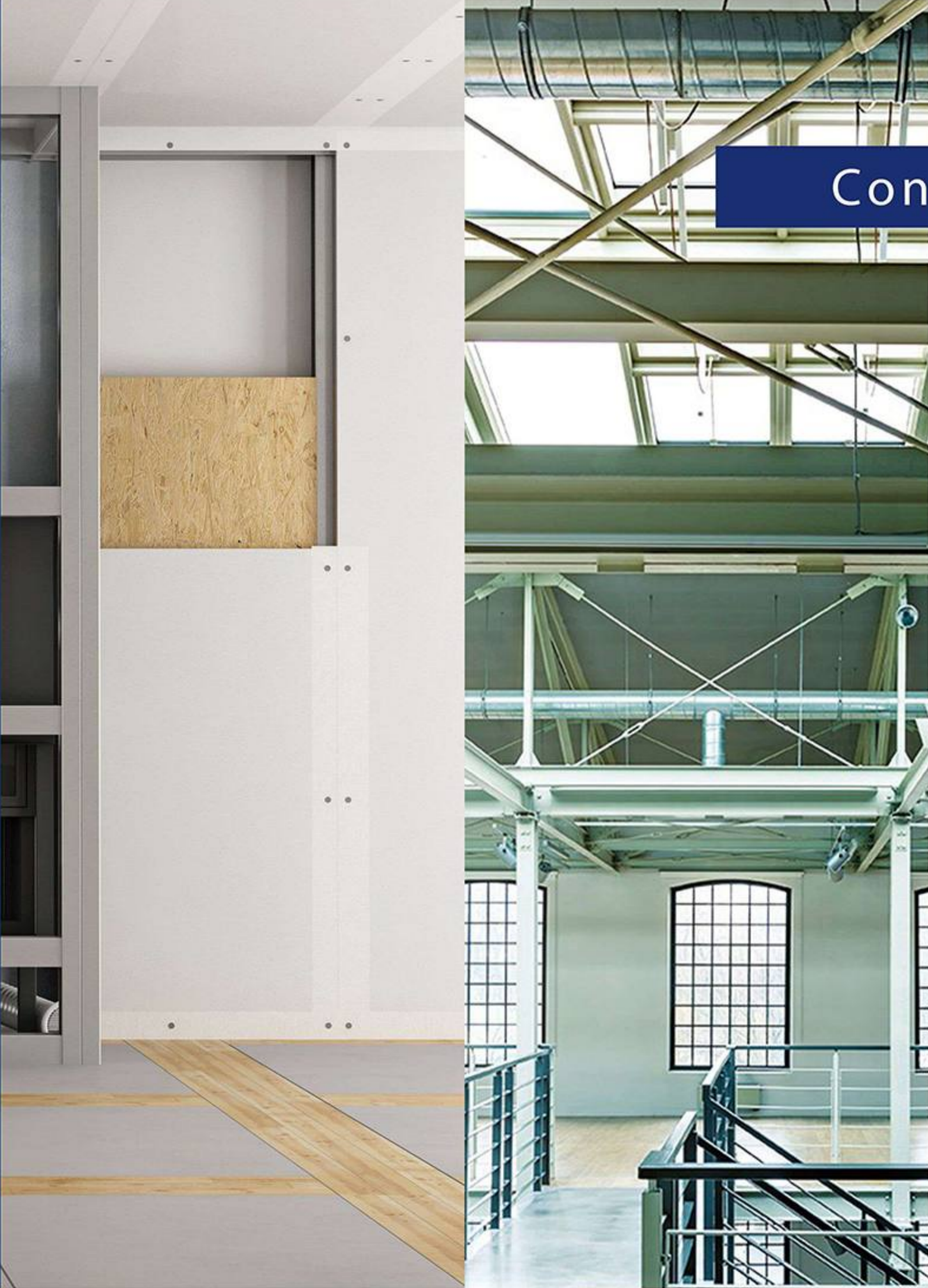

Content / Page

About Fong Prean 04

Quality 06

Technology 08

Environment 10

Patent Products 12

Main Products 28

About Fong Prean

"With our full equipped facilities and extensively experiences Research and Development team, Fong Prean stands out in devising innovation solution and customized designs to meet specific customer requirements and cater to diverse market demands."

**JOIN US!
LET US BE YOUR RELIABLE PARTNER.**

Fong Prean is a professional screw manufacturer and fastener supplier based in Taiwan since 1986, our journey began with a leased factory and has evolved to our own plant. Located within the main screw industrial cluster, it empowers us to provide a complete supply chain, including wiring, production, coating and end packing, ensuring efficient and punctual delivery.

Boasting extensive machinery and full service capabilities, Fong Prean excels in production, procurement, logistics, after-sales service, marketing and sales. Our specialization lies in developing innovative solutions and products to cater to the specific needs and challenges of end-users.

At Fong Prean, we continuously enhance our systems optimization (digital transformation), such as ERP (Enterprise Resource Planning) system integration, advanced machinery and testing equipment to integrate all departments into one system which results in workflows efficiency and transparency of information.

Furthermore, we are dedicated to researching cost-effective solutions and reducing error rates without compromising quality.

Choosing us as your reliable partner dedicated to ensuring the rights, interests and sustainable growth of each parties.

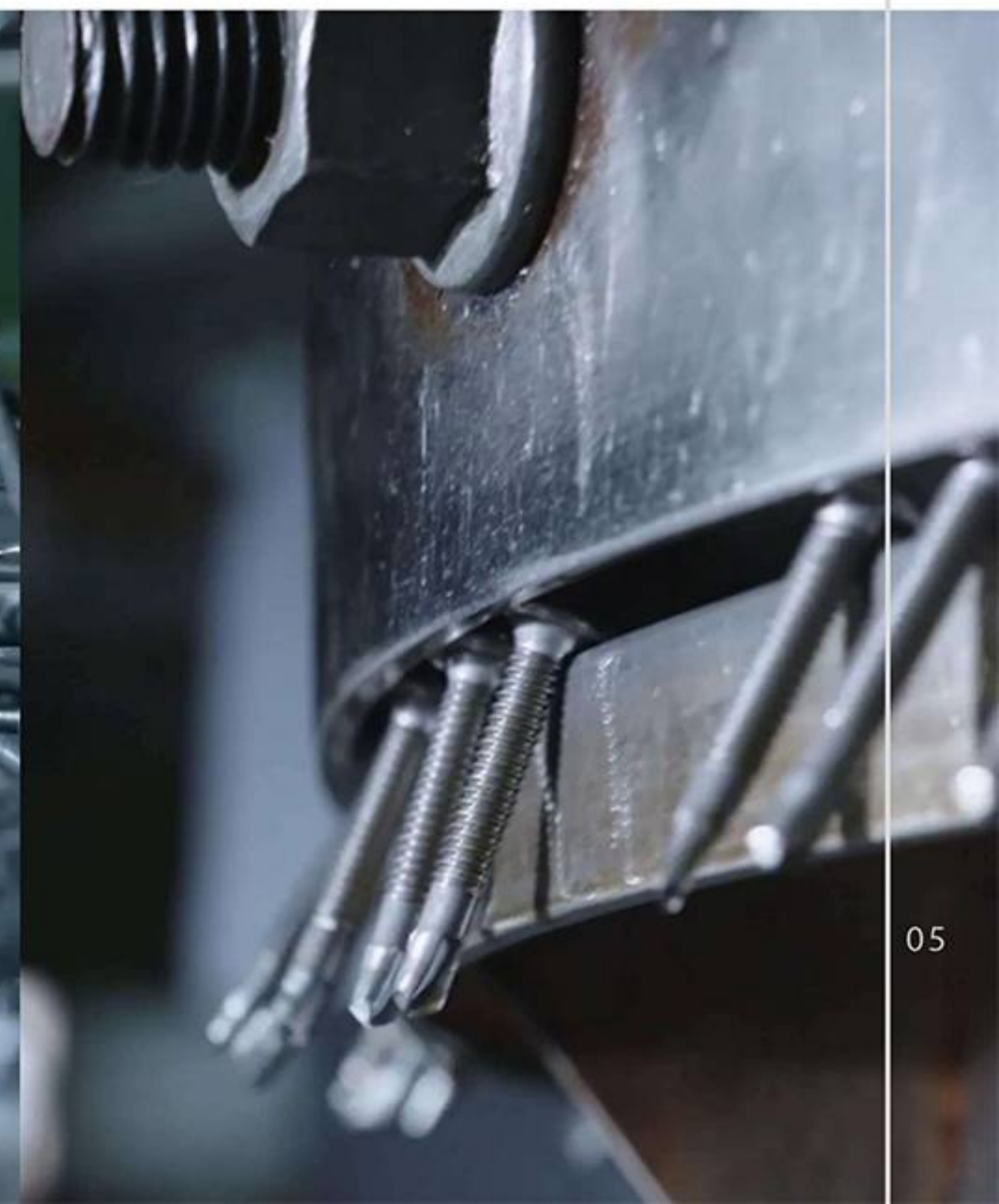

How We Work

Wire

Test and Certification of Non-Radiative Contamination.

Heading, Point, Threading

Inspections every steps.

Heat Treatment

Heat treatment in house. Inspection.

Plating and Final Inspection

QC inspection for products' test reports.

Packaging

Tracing LOT number stamp on each carton.
Heat treatment for our wooden pallets. Also provide paper pallets.

Container Stuffing

Deep clean to prevent seeds or any other pollutions



EQUIPMENT



"High Productivity, Quality Assurance and Reliable Delivery."

Equipped with advanced facilities and a commitment to continuous improvement, we are strictly controlling and testing throughout each stage. From materials to production and delivery, we meticulously inspect each step to adhere to the highest international standards. We also provide periodic assistance to our partner mills, ensuring consistent technology, reliability, and quality.



SGS ISO9001:2015 / SGS ISO14001:2015
CE EN 14592 / CE EN14566 / ETA-20/0408



R&D Technology

"Customized Design and Innovative Solution to Fulfill Market's Needs."

With over 37 years of research and design expertise, Fong Preat has successfully developed more than 18 patented innovations. We continuously gather up-to-date market intelligence and tailor our fasteners to align with new building materials, cutting-edge tool advancements, and evolving customer requirements.



Design Processes

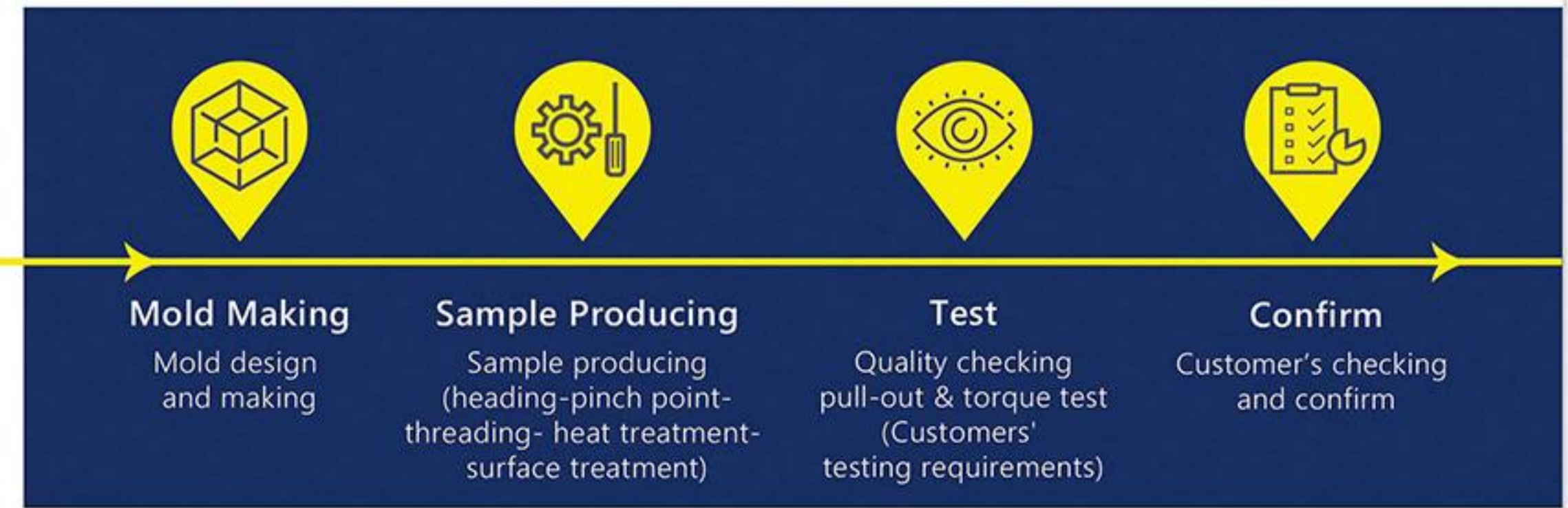

Green Business



SAVE THE PLANET

At Fong Prean, we are dedicated to ESG values. As a responsible business, we consistently improve our operations to address environmental concerns. Our focus is on sustainable development, regularly reviewing our environmental policy.

We also prioritize educating stakeholders about the importance of environmental protection. Partner with Fong Prean for responsible practices and quality solutions.



Green Energy
Solar Power



Energy Savings
Voltage Equipment



Green Building
Natural Lighting



Green Knowledge
Environmental
Education



MS TWISTER

For Wood

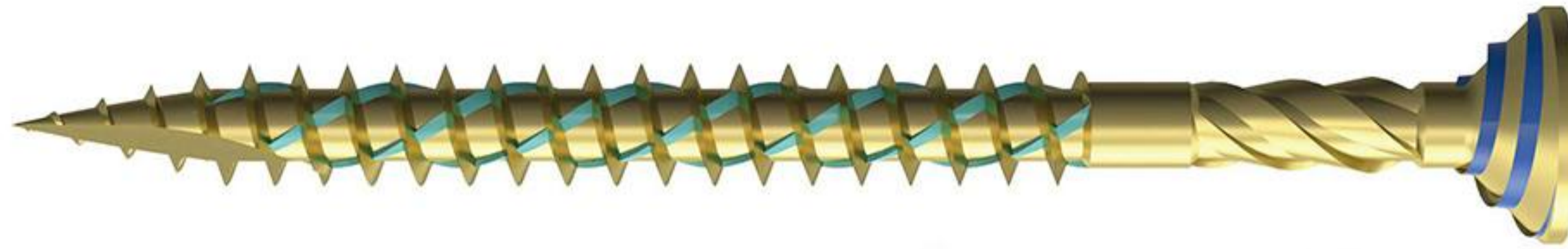

Magic Spiral

Carbon Steel · Stainless Steel

Size: M3 - M8 ; #5 - 5/16

Length: 16 - 400mm ; 5/8" - 15 3/4"

1. Low driving torque and high holding power
2. Quick start and fast penetration
3. No splitting near the edge of timber
4. Easy and clean countersinking without burrs and mushrooming
5. Stainless steel provides high corrosion resistance and durability for outdoor application

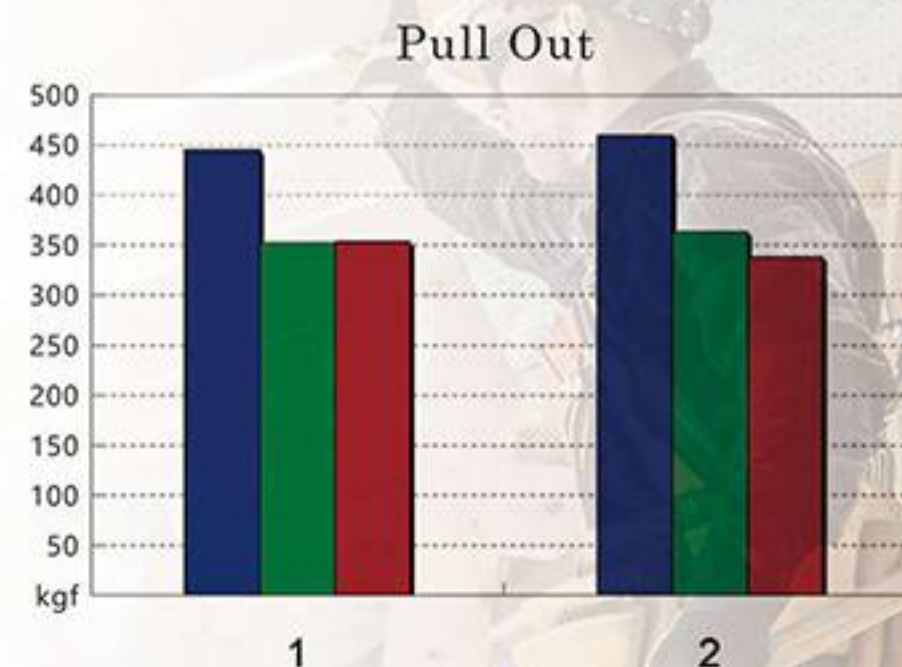
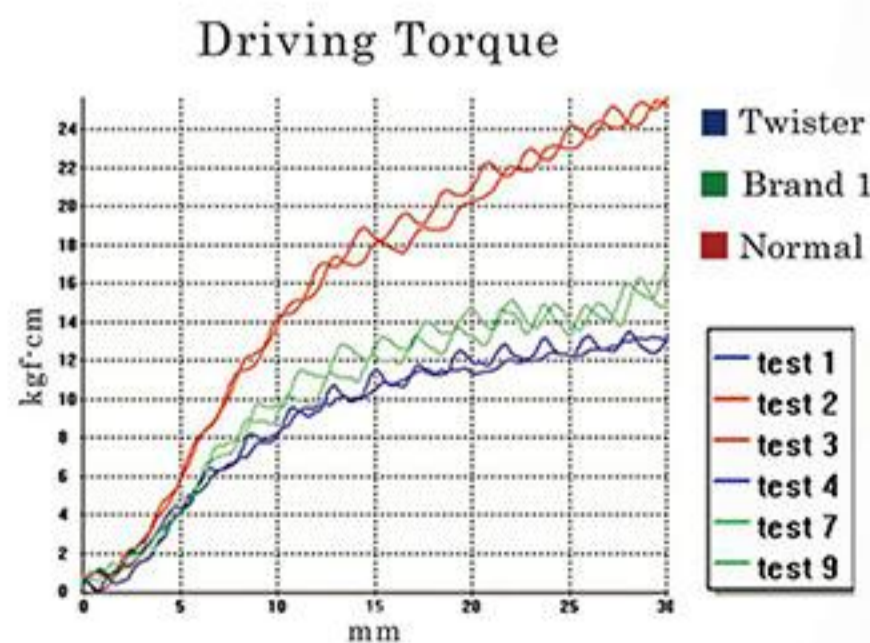

Melamine



Chipboard



MDF

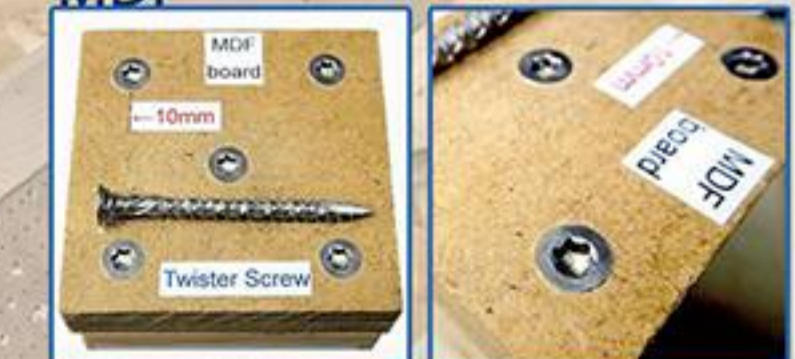



MS REAMER

For Hardwood & Hard Gypsum Board



Carbon Steel · Stainless Steel

Size: M3 - M8 ; #5 - 5/16
Length: 25 - 400mm ; 1" - 15 3/4"

1. No pre-drilling required
2. Quickly grabs and fast drilling
3. No splitting near the edge of wood
4. Perfect countersunk without burrs
5. Stainless steel with high protection against corrosion for outdoor.





GII Drywall Screw

Light Gauge Steel
to
Light Gauge Steel



Gypsum Board
to
Light Gauge Steel



Wood to Steel

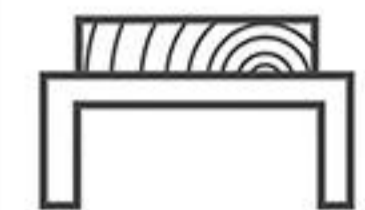

Collated Screws



Carbon Steel · Stainless Steel

Size: M3 - M8 ; #5 - 5/16

Length: 9 - 400mm ; 3/8" - 15 3/4"

GII v.s. Fine thread drywall screws Speed Test

Load: 30lbs (13.6kg) RPM: 2500rpm Metal thickness: 1.0mm

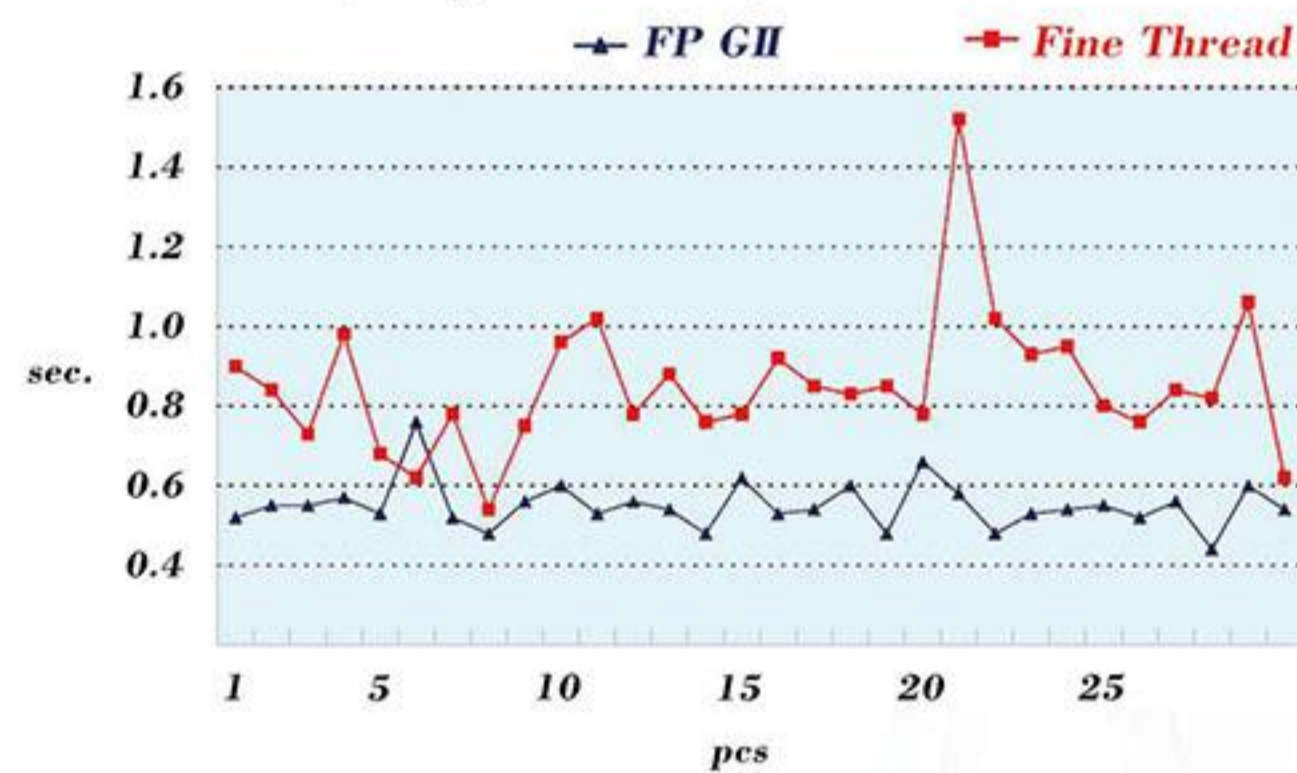

With GII special thread and point design:

1. Widely-used
2. Speedy and Stable
3. High Holding Power
4. Low Cost

We provide a customized service (including size, head style, head recess, thread and surface treatment) to solve you problems.



COUNTERSUNK 12-V-RIBS HEAD

-Fiber Cement Board to Wood

-Fiber Cement Board to Steel (with Wings)



Carbon Steel \ Stainless Steel

Size: M3 - M8 ; #5 - 5/16

Length: 9 - 300mm ; 3/8" - 11 3/4"

Point: #1 - #6 w/ wings

- 1. Special ribs under head design provides countersunk with clean and flush.
- 2. No pre-drilling required.
- 3. Start easily and drive with less torque.



6mm fiber cement board to 0.32, 0.5, 1.4mm steel



SPECIAL DRIVE RECESS

-Hex-Star Recess

-Super-Cross Recess



Carbon Steel · Stainless Steel

- 1. Fit well and stable without wobbling and cam-out.
- 2. High torsion reduce bit fracture and extends the bit life.
- 3. Better driving for load-bearing material and save your energy.

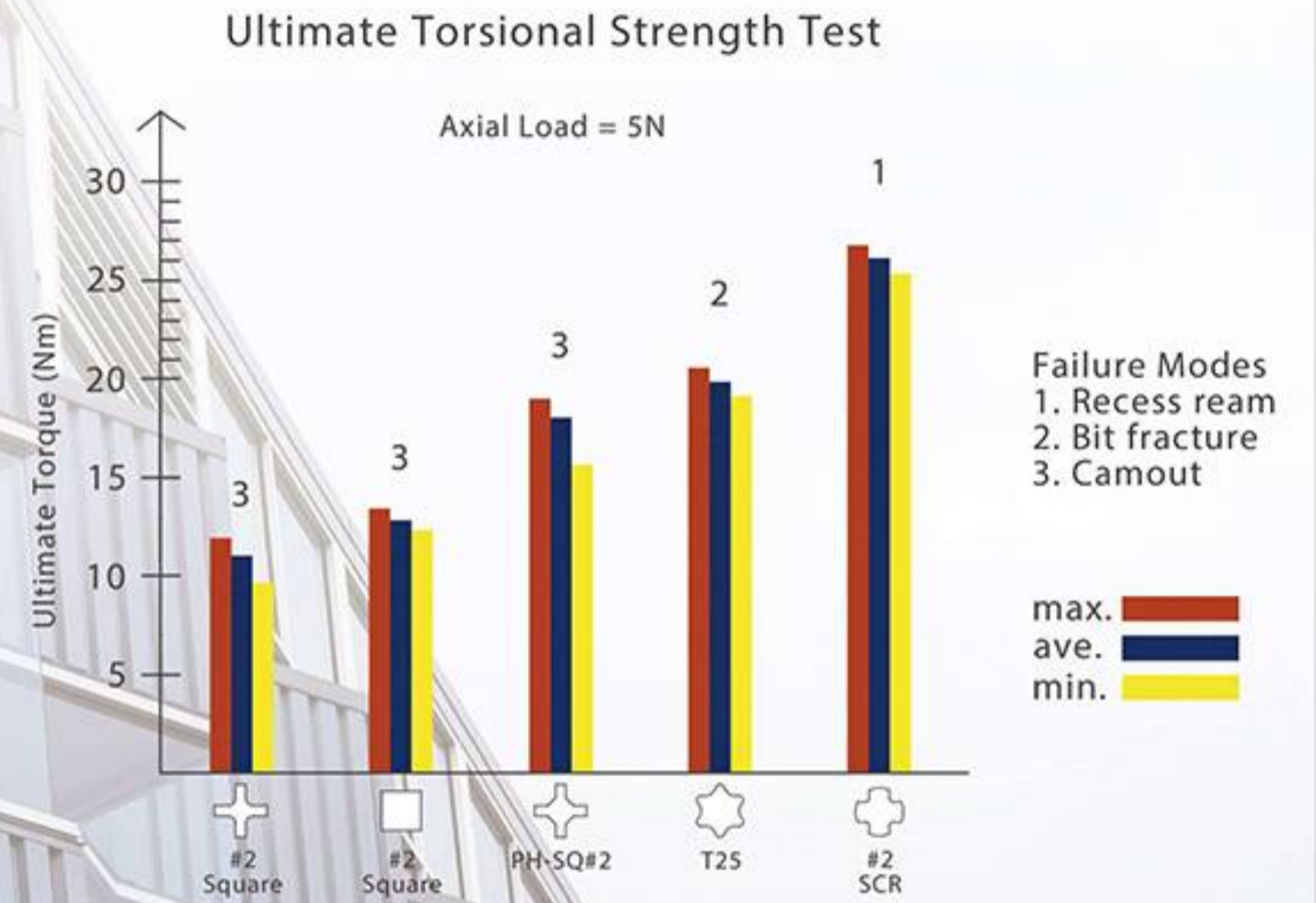

Star/six lobe and Hex bits are also available for Hex-Star recess.

We provide a customized service (including size, head style, head recess, thread and surface treatment) to solve you problems.



FP COUNTERSINK DRILL BIT SET

-Wood -Hard Wood

-WPC Board -Rubber -Plastic -Aluminum Board



Carbon Steel 、 Stainless Steel

Size: M3.8 - M6.5 ; #6 - #14

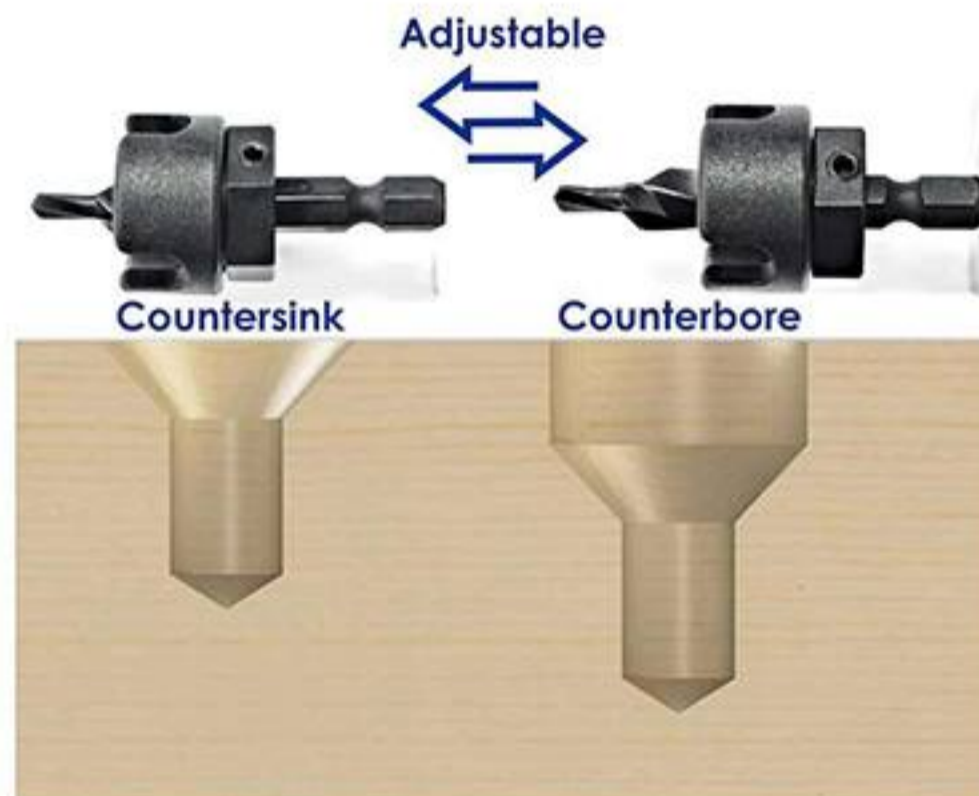

Extra Function- Screw Depth Setter

- 1. Above 50L
- 2. Adjustable depth setter
- 3. Replaceable free-spining stop collar
- 4. No surface damage

- 1. Special Tip Design- able to drill varied materials.
- 2. Drilling without chips stuck.
- 3. Replaceable stop chunk without burning, marking or scratching on the surfaces.
- 4. Adjustable depth stopper.
- 5. No burr and mushrooming.
- 6. Longer product life- 30-40% longer compared to others.



FP T-HIDDEN CLIPS COMPOSITE DECK FASTENER



Carbon Steel · Stainless Steel · Eco-friendly Nylon

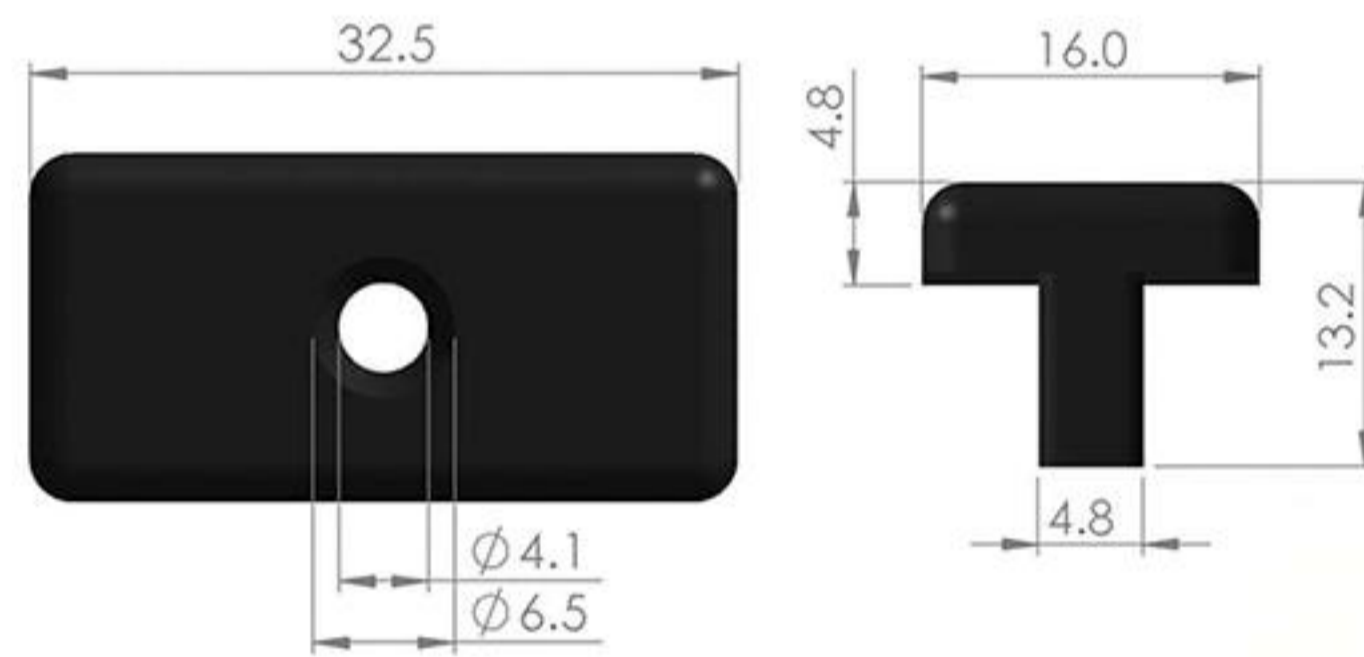

With Sharp point screw can connect decking board with timber.
With Drilling point screw provides decking board connecting with Aluminum frames (Max. 2.0mm).

1. Come with T-Hidden clips and decking screws set, increased your work efficiency
2. T-Hidden clip can customized color with head painting screw
3. Provides a clean and unblemished finish look
4. 90 degree installation, easy and quick
5. With ribs design can reduce sliding and avoid crimping, tight and stability





Drywall Cutting Bit



Carbon Steel C1022



-Sharp-cut



-Hi-Lo Thread

1. Max. Operating RPM: 30,000 PRM
2. Gives a piloted tip for making easy and clean cut-out switch boxes, air vents and others.
3. Low cost for using in drywall.
4. Perfect choice for DIY marketing.





Main Products

-High Production -Quality Assurance -Reliable Delivery

We provide a customized service, including a variety of head, recess, thread, point styles and coating, to solve you problems.

Drywall Screws / Framing Screws

S= M3 - M10, L= 9 - 400mm ; S= #5 - 3/8, L= 3/8" - 15 3/4"



Wood Screws / Decking Screws

S= M3 - M10, L= 9 - 400mm ; S= #5 - 3/8, L= 3/8" - 15 3/4"



Self Drilling Screws /w Wings

S= M3 - M8, L= 9 - 300mm ; S= #5 - 5/16, L= 3/8" - 11 3/4"

Point: #1 - #6



Roofing Screws

S= M3 - M8, L= 9 - 300mm ; S= #5 - 5/16, L= 3/8" - 11 3/4"

Point: #1 - #6 ; Stainless Cap, Color Painted Head, Washer





Main Products

-High Production -Quality Assurance -Reliable Delivery

We provide a customized service, including a variety of head, recess, thread, point styles and coating, to solve you problems.

Cement Board Screws

S= M3 - M8, L= 9 - 300mm ; S= #5 - 5/16, L= 3/8" - 1 1/4"
Point: #1 - #6 ; Hi-Lo Threads, SDS, Spoon Point, Wings



Concrete Screws

S= M3.5 - M8, L= 9 - 300mm ; S= #6 - 5/16, L= 3/8" - 1 1/4"



Self Tapping Screws

S= M3 - M8, L= 9 - 300mm ; S= #5 - 5/16, L= 3/8" - 1 1/4"



Bi-Metal Screws

S= M3.5 - M8, L= 19 - 330mm ; S= #6 - 5/16, L= 3/4" - 1 1/2"
Point: #1 - #8



Stainless Steel Screws

A2, A4 ; 302, 305, 316, 410



Collated / Coil Screws

S= M3.5 - M6, L= 16 - 75mm ; S= #6 - 1/4, L= 5/8" - 3"
Sharp point, Drilling point

